



## L-GAGE™ Laser Gauging Sensors (Analog Voltage Output)

Class 2 visible laser displacement sensor with both analog and discrete (switched) outputs



### L-GAGE Laser Gauging Sensor Features

- Self-contained Class 2 modulated visible laser gauging sensor needs no separate controller
- Narrow effective beam is excellent for precision gauging applications or for distance, height, or thickness measurement
- Resolution to better than 3 microns for LG5 Series models, and better than 10 microns for LG10 Series models
- Banner's unique scalable analog output\* automatically distributes the output signal over the width of the programmed sensing window
- Analog and discrete (switched) outputs with independent window limits
- Analog output slope is either positive or negative, depending upon which window limit is programmed first
- Fast, easy-to-use integrated push-button TEACH-mode programming; no potentiometer adjustments – Remote TEACH function for security and convenience
- Unique feature holds analog output value for 2 seconds upon loss of signal
- Modulated laser beam and narrow optical band-pass filter provide a high level of ambient light immunity, including immunity from high-energy factory lighting
- Alarm output for signal saturation and overload of discrete output
- Output response is programmable for three speeds

\* Patent Pending

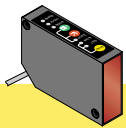

### L-GAGE Laser Gauging Sensor Analog Voltage Output Models

Models	Sensing Distance	Focal Point†	Cable*	Supply Voltage	Discrete Output	Analog Output		
LG5A65PU	45 to 60 mm (1.8" to 2.4")	70 mm (2.8") Beam size at 53 mm 0.4 mm x 0.6 mm (0.016" x 0.024")	2 m (6.5') (8-wire)	12 to 30V dc	PNP (Sourcing)	Analog Voltage (0 to 10V dc)		
LG5A65PUQ			Pigtail QD (8-pin Euro)					
LG5A65NU			2 m (6.5') (8-wire)		NPN (Sinking)			
LG5A65NUQ			Pigtail QD (8-pin Euro)					
LG5B65PU		53 mm (2.1") Beam size at 53 mm 0.1 mm (0.004")	2 m (6.5') (8-wire)		PNP (Sourcing)			
LG5B65PUQ			Pigtail QD (8-pin Euro)					
LG5B65NU			2 m (6.5') (8-wire)		NPN (Sinking)			
LG5B65NUQ			Pigtail QD (8-pin Euro)					
LG10A65PU	75 to 125 mm (2.9" to 4.9")	180 mm (7.1") Beam size at 125 mm 0.06 mm x 0.8 mm (0.024" x 0.031")	2 m (6.5') (8-wire)		12 to 30V dc		PNP (Sourcing)	Analog Voltage (0 to 10V dc)
LG10A65PUQ			Pigtail QD (8-pin Euro)					
LG10A65NU			2 m (6.5') (8-wire)				NPN (Sinking)	
LG10A65NUQ			Pigtail QD (8-pin Euro)					

\*NOTE: 9 m (30') cables are available by adding suffix "W/30" to the model number of any cabled sensor (e.g., LG10A65NU W/30).

†The Focal Point is the distance measured from the lens (front of sensor) at which the diameter of the laser image is smallest (see Figure 2).

# L-GAGE™ Laser Gauging Sensors – Analog Voltage Output

## L-GAGE Laser Gauging Sensor Overview

Banner's Class 2 visible laser displacement sensor brings a sophisticated yet cost-effective solution to precision measurement applications. L-GAGE Series sensors feature all-in-one design and require no separate controller.

Near and far sensing window limits are set quickly using simple push-button or remote signal TEACH-mode programming. One sensor can simultaneously provide both analog and discrete (switched) outputs. Sensing window limits for each output may be independently programmed. The analog signal features Banner's unique scalable output (patent pending), which automatically distributes the 0 to 10V dc output signal over the width of the programmed sensing window.

The L-GAGE Laser Gauging Sensor boasts many additional features, including selectable response speed, self-diagnostics with alarm output, comprehensive status indicator system, and unique output "hold" function in case of momentary signal loss in profiling applications.

## Optical Triangulation

The design of the L-GAGE Laser Gauging Sensor is based on optical triangulation (see figure 1). An emitter transmits visible laser light through a lens, toward a target. The laser light beam from the emitter bounces off the target, scattering some of its light through another lens to the sensor's PSD (position-sensitive device) receiver element. The target's distance from the receiver determines the angle the light travels to the receiver element; this angle in turn determines where the received light will fall along the PSD receiver element.

The position of the light on the PSD receiver element is processed through analog and digital electronics and analyzed by the microprocessor, which calculates the appropriate output value. The analog output provides a variable 0 to 10V dc signal that is proportional to the target's position within the user-programmed analog window limits (see page 9). The discrete (switched) output energizes whenever the target is located between the user-programmed discrete window limits. Analog and discrete window limits may be the same, or programmed independently.

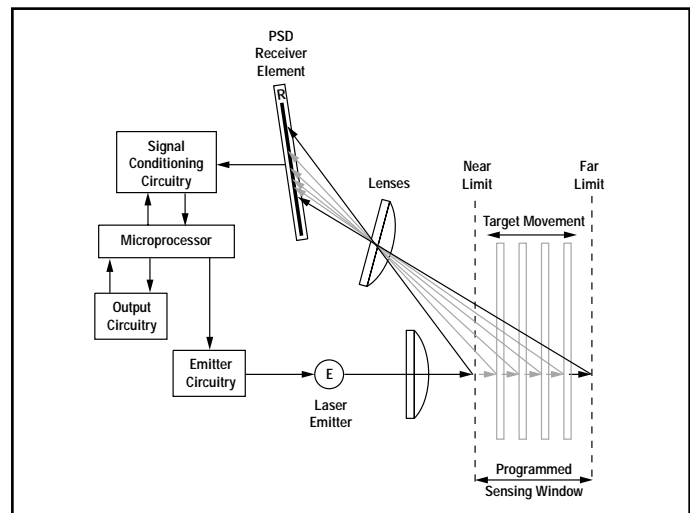

Figure 1. Optical triangulation sensing system overview

# L-GAGE™ Laser Gauging Sensors – Analog Voltage Output

## L-GAGE Laser Gauging Sensor Analog Voltage Output Specifications

<b>Sensing Range</b>	<b>LG5:</b> 45 to 60 mm (1.77" to 2.36")	<b>LG10:</b> 75 to 125 mm (2.95" to 4.92")
<b>Supply Voltage</b>	12 to 30V dc (10% maximum ripple); 50 mA max @ 24V dc (exclusive of load)	
<b>Supply Protection Circuitry</b>	Protected against reverse polarity and transient overvoltages	
<b>Delay at Power-up</b>	1.25 second	
<b>Sensing Beam</b>	670 nm visible red IEC and CDRH Class 2 laser; 0.20 mW radiant output power	
<b>Output Configurations</b>	<b>Discrete (switched) and alarm outputs:</b> SPST solid-state switch; choose NPN (current sinking) or PNP (current sourcing) models <b>Analog output:</b> 0 to 10V dc or 10 to 0V dc (voltage sourcing)	
<b>Output Ratings</b>	<b>Discrete (switched) and Alarm outputs:</b> 100 mA maximum <b>OFF-state leakage current:</b> less than 5 microamps <b>Output saturation voltage</b> <b>PNP outputs:</b> less than 1.2 volts at 10 mA and less than 1.6 volts at 100 mA <b>NPN outputs:</b> less than 200 millivolts at 10 mA and less than 600 millivolts at 100 mA <b>Analog output:</b> 2.5 kΩ minimum load impedance	
<b>Output Protection</b>	Discrete and alarm outputs are protected against continuous overload and short circuit	
<b>Output Response Time</b>	<b>Discrete Outputs</b> <b>Fast:</b> 2.0 milliseconds ON and OFF <b>Medium:</b> 10 milliseconds ON and OFF <b>Slow:</b> 100 milliseconds ON and OFF <b>Analog Output (-3dB)</b> <b>Fast:</b> 450 Hz (1 millisecond average with 1 millisecond update rate) <b>Medium:</b> 45 Hz (10 millisecond average with 2 millisecond update rate) <b>Slow:</b> 4.5 Hz (100 millisecond average with 5 millisecond update rate)	
<b>Analog Resolution and Repeatability of Discrete Trip Point*</b> Also see Figures 3 and 6	<b>LG5:</b> Fast: < 40 microns @ 50 mm Medium: < 12 microns @ 50 mm Slow: < 3 microns @ 50 mm	<b>LG10:</b> Fast: < 150 microns @ 100 mm Medium: < 50 microns @ 100 mm Slow: < 10 microns @ 100 mm
<b>Analog Linearity*</b> *Resolution and linearity specified @ 24V dc, 22° C, using a white ceramic test surface (see Application Notes)	<b>LG5:</b> +/- 60 microns (+/- 0.002") over 45 to 60 mm sensing window +/- 10 microns (+/- 0.0003") over 49 to 51 mm sensing window	<b>LG10:</b> +/- 200 microns (+/- 0.008") over 75 to 125 mm sensing window +/- 20 microns (+/- 0.0008") over 95 to 100 mm sensing window
<b>Minimum Window Size (Analog or Discrete)</b>	<b>LG5:</b> 1.5 mm (0.06")	<b>LG10:</b> 5 mm (0.2")
<b>Hysteresis (Discrete Output)</b>	<b>LG5:</b> < 0.2 mm (0.008")	<b>LG10:</b> < 1.0 mm (0.04")
<b>Color Sensitivity (typical)</b>	<b>LG5:</b> < 75 microns (0.003") for white to dark grey ceramic target	<b>LG10:</b> < 100 microns (0.004") for white to dark grey ceramic target
<b>Temperature Drift</b>	<b>LG5:</b> +/- 7 microns/°C	<b>LG10:</b> +/- 25 microns/°C
<b>Remote TEACH and Laser Control Input Impedance</b>	18 kΩ minimum (65 kΩ at 5V dc)	
<b>Laser Control</b>	<b>To enable laser:</b> Connect green wire to +5 to 30V dc <b>To disable laser:</b> Connect green wire to 0 to +2V dc (or open connection) 250 millisecond delay upon enable/disable	
<b>Remote TEACH</b>	<b>To teach:</b> Connect yellow wire to +5 to 30V dc <b>To disable:</b> Connect yellow wire to 0 to +2V dc (or open connection) See Remote Programming on pages 7 and 8.	
<b>Adjustments</b>	<b>Response speed:</b> Push button toggles between Slow, Medium, and Fast (see Output Response Time) <b>Window limits (analog or discrete):</b> TEACH-mode programming of near and far window limits (see programming procedure). Limits may also be taught remotely (see pages 7 and 8). <b>Analog output slope:</b> The first limit taught is assigned to the minimum analog output (0V dc).	

# L-GAGE™ Laser Gauging Sensors – Analog Voltage Output

## L-GAGE Laser Gauging Sensor Specifications (continued)

<b>Indicators</b>	<p><b>Green Power ON LED:</b> Indicates when power is ON, overloaded output and laser status.</p> <p><b>Yellow Output LED:</b> Indicates when discrete load output is conducting.</p> <p><b>Red Signal LED:</b> Indicates when target is within sensing range and the condition of the received light signal.</p> <p><b>Tri-color Red/Green/Yellow TEACH LED:</b> Indicates sensor is ready for programming each limit (indicates red for analog output, green for discrete, and yellow for simultaneous analog and discrete.)</p> <p><b>Yellow Fast/Slow LEDs:</b> Combination of 2 lights ON or OFF indicates 1 of 3 response speeds (see page 6).</p> <p>NOTE: See page 9 for more information on indicator behavior.</p>
<b>Construction</b>	<p><b>Housing:</b> Zinc alloy die-cast, plated and painted finish</p> <p><b>Cover plate:</b> aluminum with painted finish</p> <p><b>Lens:</b> acrylic</p>
<b>Environmental Rating</b>	IP67, NEMA 6
<b>Connections</b>	2 m (6.5') or 9 m (30') 7-conductor shielded PVC-jacketed attached cable, or 150 mm (6") 8-pin Euro-style pigtail quick-disconnect. Mating QD cables are purchased separately (see page 12).
<b>Operating Conditions</b>	<p><b>Temperature:</b> -10° to +50° C (+14° to 122° F)</p> <p><b>Maximum relative humidity:</b> 90% at 50° C, non-condensing</p>
<b>Vibration and Mechanical Shock</b>	<p><b>Vibration:</b> 60 Hz, 30 minutes, 3 axes</p> <p><b>Shock:</b> 30G for 11 milliseconds, half sine wave, 3 axes</p>
<b>Application Notes</b>	For comparison, a white ceramic test surface has approximately 91% of the reflectivity of a white Kodak test card with a matte finish. A dark gray ceramic test surface has approximately 11% of the reflectivity of a white Kodak test card with a matte finish. (Allow 15-minute warm-up for maximum linearity.)

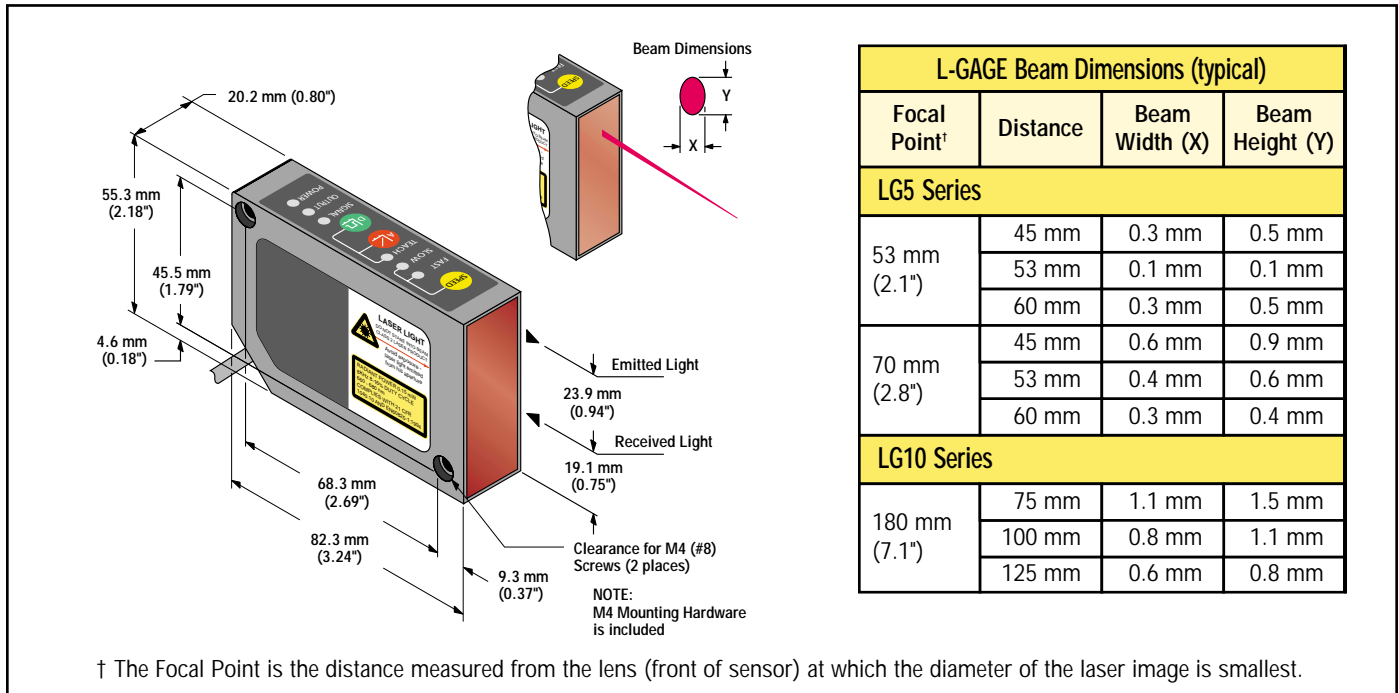

Figure 2. L-GAGE Laser Gauging Sensor and beam dimensions

# L-GAGE™ Laser Gauging Sensors – Analog Voltage Output

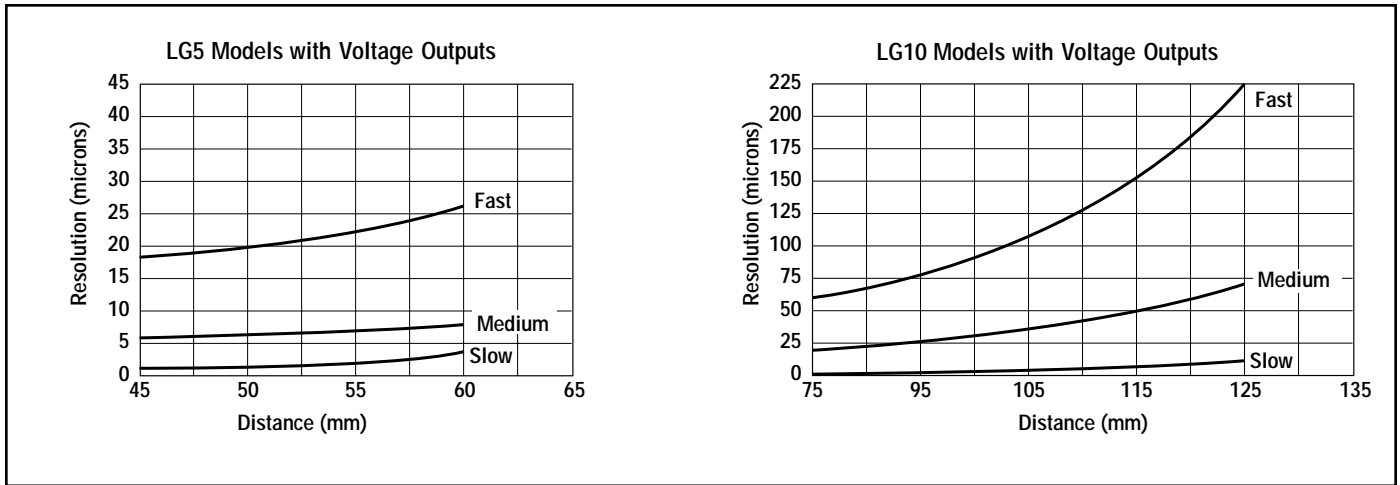
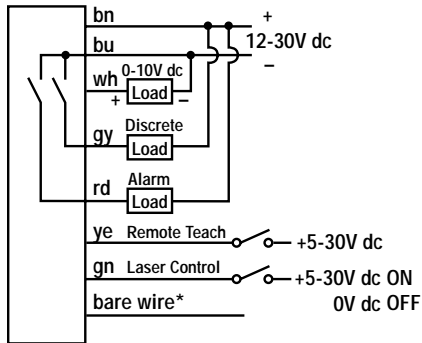

Figure 3. L-GAGE resolution, with respect to speed (typical, using a white ceramic target)

## L-GAGE Laser Gauging Sensor Analog Voltage Output Hookups

### NPN Hookup



### PNP Hookup

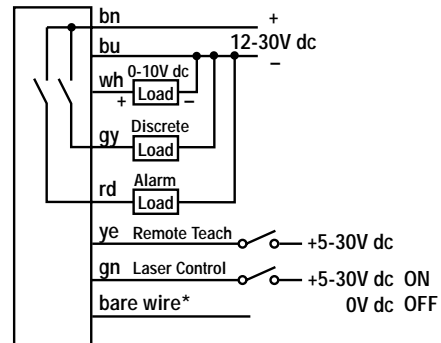

NOTE: Hookups are the same for either integral or QD cable

### 8-pin Euro-style Pin-out (connector on cable shown)

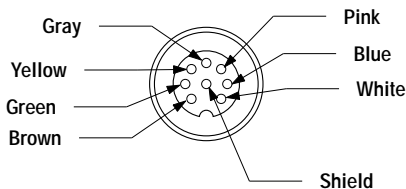

\*NOTE: The bare shield wire is connected internally to the sensor housing and should be connected as follows:

- 1) If the sensor housing is mounted so that it is in continuity with both the machine frame and earth ground, connect the bare wire (also) to earth ground.
- 2) If the sensor housing is mounted so that it is insulated from the machine frame, connect the bare wire to -V dc (together with the blue wire).
- 3) If the sensor is mounted so that it is in continuity with the machine frame, but not with earth ground, do not connect the bare wire (i.e. cut off the bare wire).

# L-GAGE™ Laser Gauging Sensors – Analog Voltage Output

## Using the L-GAGE Laser Gauging Sensor

### Modes

The L-GAGE Laser Gauging Sensor operates in two modes: TEACH (or programming) and RUN.

### TEACH-Mode Programming

#### Response Speed

Use the Speed push button to toggle between the three response speed settings. The combination of indicator lights (Fast and Slow) will tell you which of the three is selected:

Slow	Fast	Analog Output Frequency Response (-3dB)	Discrete Output Response Speed
ON	OFF	4.5 Hz	100 milliseconds
ON	ON	45 Hz	10 milliseconds
OFF	ON	450 Hz	2 milliseconds

#### Window Limits

Window limits may be taught to the sensor in several ways. The following methods describe the TEACH procedures for programming using the sensor push buttons; remote programming (remote TEACH) procedures are described on page 7.

#### Teaching Limits for Either Analog or Discrete Output

1. Choose the output for the first set of window limits (analog or discrete) and push and hold the corresponding button until the tri-color TEACH LED turns ON (solid). This indicates the sensor is waiting for the first limit: red for analog output, or green for discrete output.
2. Position the target for the first limit and briefly “click” the same button. This will teach the sensor the first limit. The TEACH LED will flash at 2Hz to acknowledge receiving the first window limit; it is now waiting for the second limit.
3. Position the target for the second limit and “click” the button again. This will teach the sensor the second limit. The TEACH LED will turn OFF to indicate that the sensor will now function in normal RUN mode.
4. Repeat for the other output (analog or discrete) if a second output is desired.

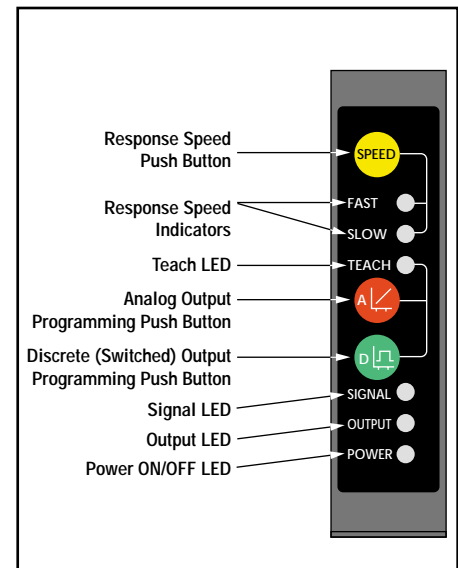

Figure 4. L-GAGE™ Laser Gauging Sensor programming push buttons and indicators

# L-GAGE™ Laser Gauging Sensors – Analog Voltage Output

---

## Teaching Analog Limits Using the Auto-Zero Feature (Analog Output)

For some analog applications, a sensing distance set point centered within a sensing window may be required. The TEACH procedure is simple: teaching the same limit twice causes the sensor to program a window centered on the position taught. This window is 10 mm wide (taught position  $\pm$  5 mm).

## Teaching Fixed-Field Sensing Mode (Discrete Output)

Teaching the same limit twice creates a sensing window with the far limit at the teach distance and the near limit at the minimum operating range of the sensor (approx. 42 mm for LG5 Series models, and approx. 60 mm for LG10 Series models).

## Teaching Limits for Both Analog and Discrete Outputs Simultaneously

To set both discrete and analog outputs at exactly the same limits, set both simultaneously.

1. Push and hold either the Analog or the Discrete programming push button until the tri-color TEACH LED turns ON. "Click" the other button (Analog or Discrete). The TEACH LED turns Yellow. The sensor is waiting for the first limit.
2. Position the target for the first limit and "click" either TEACH button. The TEACH LED will flash at 2Hz, alternating red and green, to acknowledge receiving the first window limit; it is now waiting for the second limit.
3. Position the target for the second limit and "click" either button to teach the sensor the second limit. The TEACH LED will turn OFF to indicate that the sensor will now function in normal RUN mode.

## Remote Programming

To program the sensor remotely or to disable the keypad, the Remote Programming function may be used. Disabling the keypad prevents anyone on the production floor from adjusting any of the programming settings. Connect the yellow wire of the L-GAGE Laser Gauging Sensor to +5 to 30V dc, with a remote programming switch connected between them. NOTE: The impedance of the remote teach input is 18 k $\Omega$  minimum (65 k $\Omega$  minimum at 5V).

Programming is accomplished by following the sequence of input pulses, following the button-pushes and "clicks" for programming on the sensor buttons. The duration of each pulse (corresponding to a push button "click"), and the period between multiple pulses, are defined as: 0.04 seconds < T < 0.8 seconds.

To access each of the programming modes, pulse the remote switch a prescribed

# L-GAGE™ Laser Gauging Sensors – Analog Voltage Output

number of times:

- 1 pulse: Discrete TEACH Mode
- 2 pulses: Analog TEACH Mode
- 3 pulses: Dual Discrete/Analog TEACH Mode
- 4 pulses: Disables (locks out) or enables the keypad for security

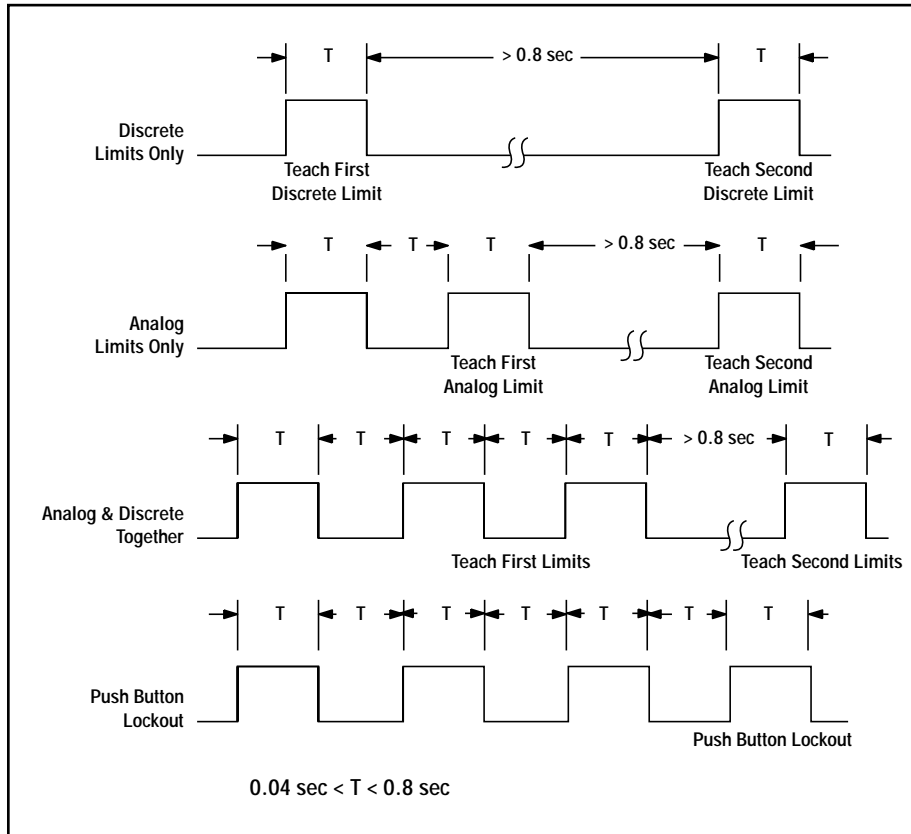

Figure 5. Timing programs for remote TEACH programming



# L-GAGE™ Laser Gauging Sensors – Analog Voltage Output

## RUN Mode

### Signal LED

The Signal LED indicates the strength and condition of the sensor's incoming signal.

Signal LED Status	Indicates
OFF	No signal is received, or the target is beyond the range limitations of the sensor (with some tolerance beyond the recommended minimum and maximum sensing distance)
Flashing @ 2Hz	Received signal is adequate for processing
Flashing @ 10Hz	Received signal is in saturation (i.e., signal is too strong); alarm output energizes
ON Solid	Received signal is within the nominal conditions for the sensor

### Output LED

The Output LED lights when the discrete output is conducting.

### Power ON/OFF LED

The Power ON/OFF LED indicates the operating status of the sensor.

Power ON/OFF LED	Indicates
OFF	Power is OFF
Flashing @ 2Hz	Discrete or alarm output is overloaded
Flashing @ 1Hz	Power ON, Laser is disabled
ON Solid	Sensor is operating normally (power is ON, Laser enabled)

### Power Up/Laser Enable

When powering up the sensor, the following should occur:

- All LEDs turn ON for 1 second
- Allow 1.25 second delay for Laser Enable at power up. (If sensor is already powered up, allow 0.25 second for Laser Enable.)

## Analog Output

The L-GAGE Laser Gauge may be programmed for either a positive or a negative output slope, based on which condition is taught first (see Figure 6). If the near limit is taught first, the slope will be positive; if the far limit is taught first, the slope will be negative. Banner's unique scalable analog output (patent pending) automatically distributes the output signal over the width of the programmed sensing window. Factory analog output is 0 to 10V dc.

The L-GAGE also features a 2-second hold upon loss of the analog signal, which is useful for profiling and similar applications. In the event of analog signal loss for longer than 2 seconds, the analog output goes to 0V dc.

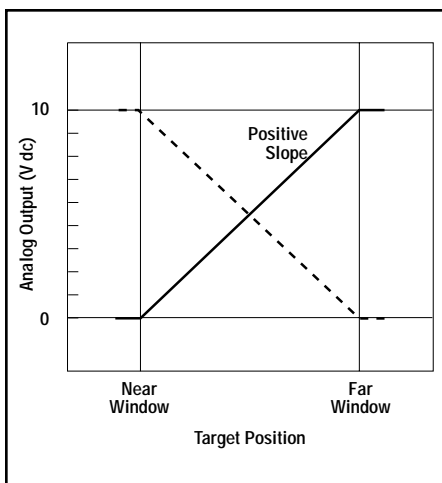

Figure 6. Analog output as a function of target position

# L-GAGE™ Laser Gauging Sensors – Analog Voltage Output

## Installation Notes

Some targets (those with a stepped plane facing the sensor, a boundary line, or rounded targets) pose specific problems for sensing distances. For such applications, see figure 7 for suggested mounting orientations.

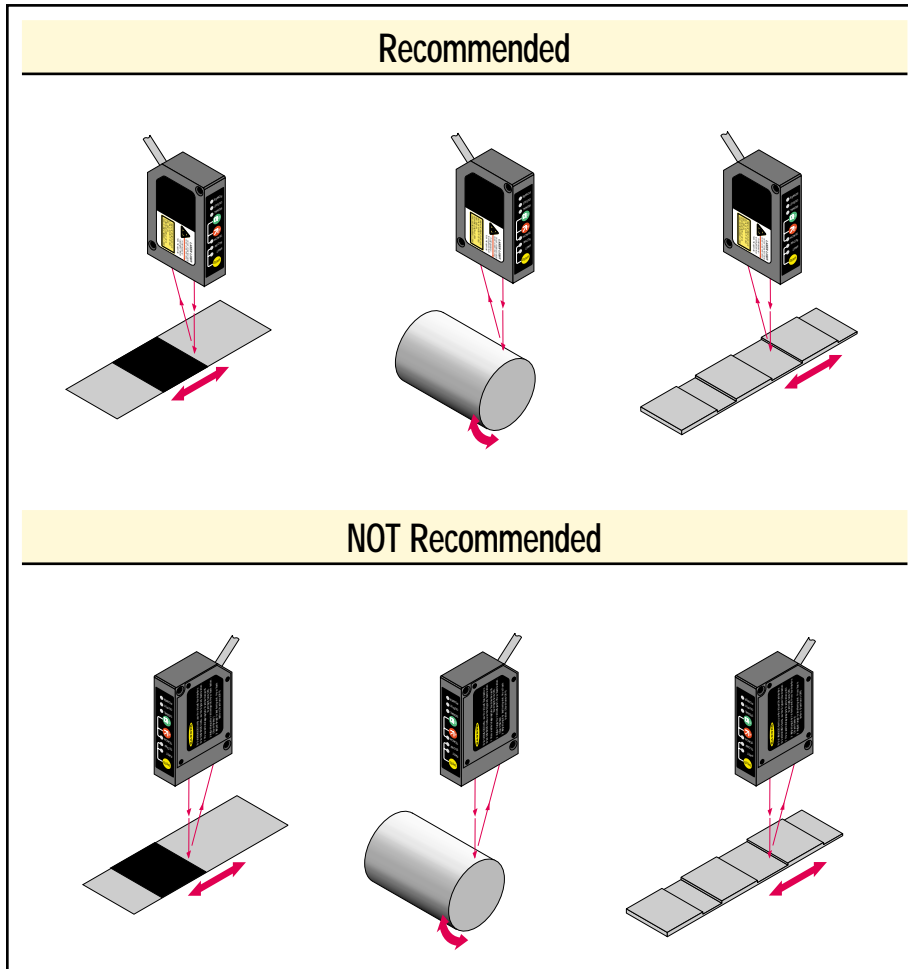

Figure 7. Sensor orientations for typical targets

## Class 2 Safety Notes

Low-power lasers are by definition incapable of causing eye injury within the duration of the blink, or aversion response of 0.25 seconds. They must also emit only visible wavelengths (400-700 nm). Therefore, an ocular hazard can only exist if an individual overcomes their natural aversion to bright light and stares directly into the laser beam. The product requirements for these lasers are to have a [hazard] label and to have an indicator light to indicate laser emission.

The two operational safety rules are:

- Do not permit a person to stare at the laser from within the beam
- Do not point the laser at a person's eye at close range

### Beam Paths:

The beam emitted by a class 2 laser product should be terminated at the end of its useful path. Open laser beam paths should be located above or below eye level where practical.

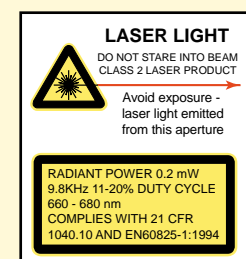

**CAUTION . . .** This sensor contains no user-servicable components. Do not attempt to repair. Incorrect component values may produce hazardous laser radiation levels.

# L-GAGE™ Laser Gauging Sensors – Analog Voltage Output

## Mounting Brackets

SMBLG

- L-GAGE sensor mounting bracket
- 304 Stainless Steel

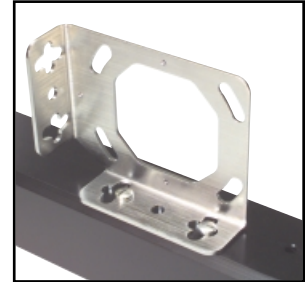
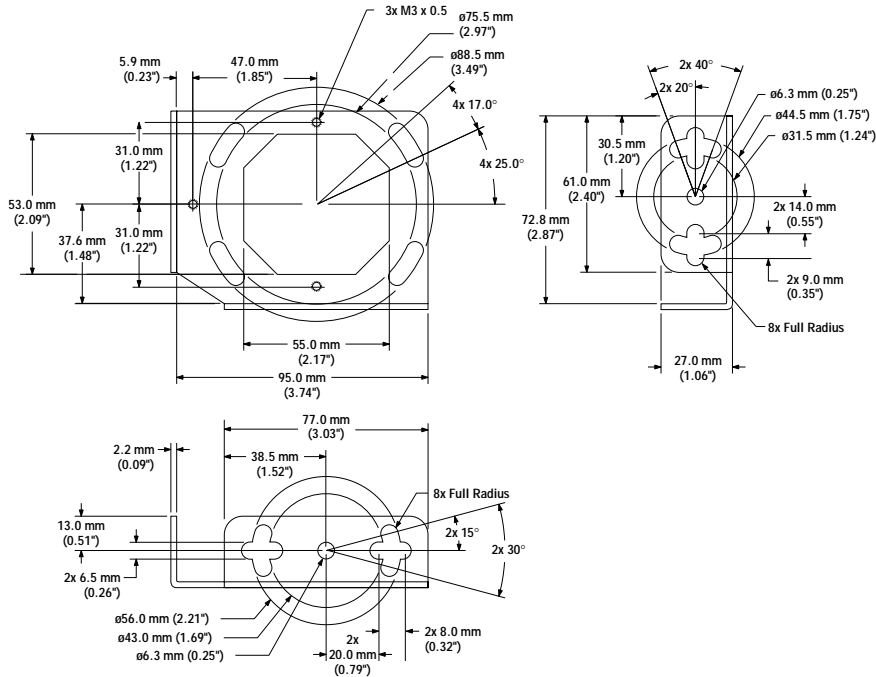

SMBLGA

- L-GAGE adjustable bracket assembly
- 304 Stainless Steel

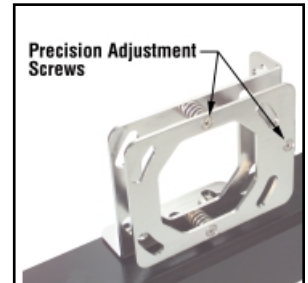
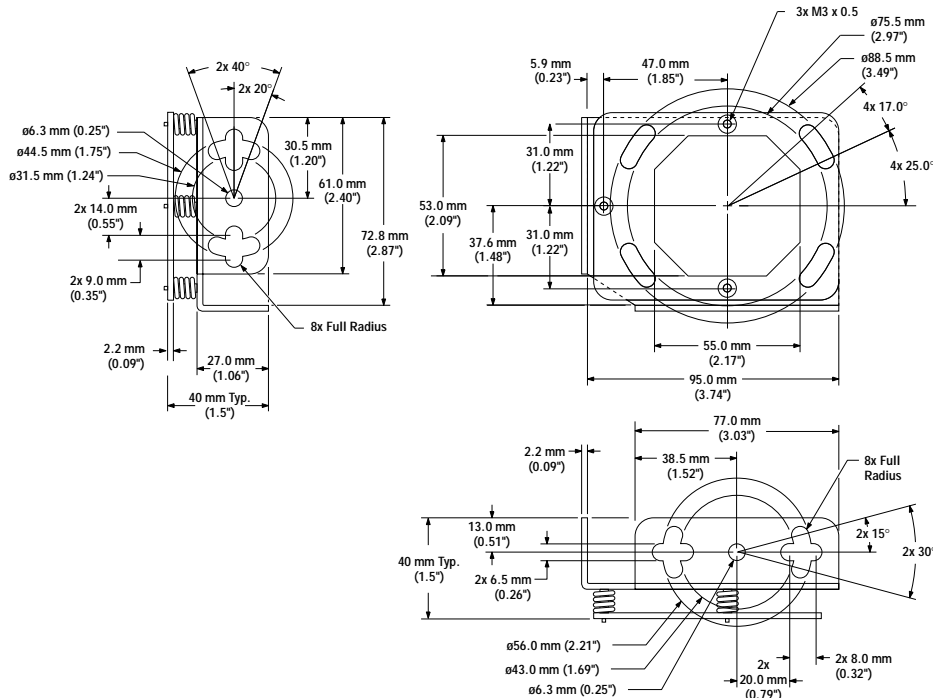

# L-GAGE™ Laser Gauging Sensors – Analog Voltage Output

## Euro-Style Quick-Disconnect Cables

**Cable:** PVC jacket, polyurethane connector body, chrome-plated brass coupling nut  
**Conductors:** 24 AWG high-flex stranded, PVC insulation, gold-plated contacts  
**Temperature:** -40° to +105°C (-40° to +221°F)  
**Voltage Rating:** 30V ac/36V dc

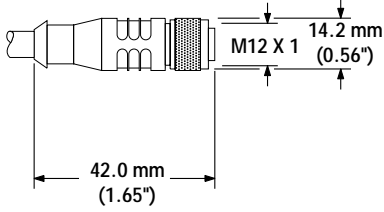
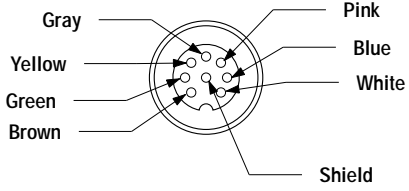
Style	Model	Length	Dimensions	Pin-out
8-Pin Straight	MQDC-830	9 m (30')		



### WARNING . . . Not To Be Used for Personnel Protection

Never use these products as sensing devices for personnel protection. Doing so could lead to serious injury or death.

These sensors do NOT include the self-checking redundant circuitry necessary to allow their use in personnel safety applications. A sensor failure or malfunction can cause either an energized or de-energized sensor output condition. Consult your current Banner Safety Products catalog for safety products which meet OSHA, ANSI and IEC standards for personnel protection.

**WARRANTY:** Banner Engineering Corp. warrants its products to be free from defects for one year. Banner Engineering Corp. will repair or replace, free of charge, any product of its manufacture found to be defective at the time it is returned to the factory during the warranty period. This warranty does not cover damage or liability for the improper application of Banner products. This warranty is in lieu of any other warranty either expressed or implied.